

# Agilent HEDS-974x Series for 180, 300, 360 LPI Small Optical Encoder Modules Data Sheet

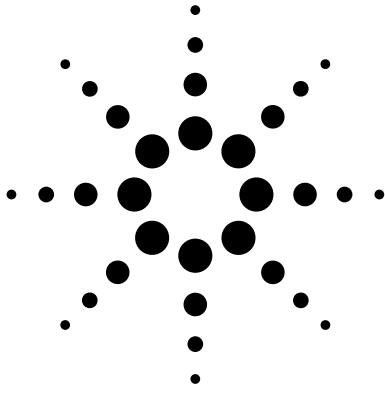

## Description

The HEDS-974x series is a high performance, low cost, optical incremental encoder module. When operated in conjunction with code-strip, this module detects linear position. The module consists of a lensed LED source and a detector IC enclosed in a small C-shaped plastic package. Due to a highly collimated light source and a unique photodetector array, the module is extremely tolerant to mounting misalignment.

The two-channel digital outputs and 5 V supply input are accessed through four solder-plated leads located on 2.54 mm (0.1 inch) centers.

## Applications

The HEDS-974x provides sophisticated motion detection at a low cost, making close-loop control very cost-competitive! Typical applications include printers, plotters, copiers, and office automation equipment.

**Note:** Agilent Technologies encoders are not recommended for use in safety critical applications. Eg. ABS braking systems, power steering, life support systems and critical care medical equipment.

Please contact sales representative if more clarification is needed.

## Theory of Operation

The HEDS-974x is a C-shaped emitter/detector module. Coupled with a codewheel, it translates rotary motion into a two-channel digital output. Coupled with a codestrip, it translates linear motion into digital outputs.

As seen in the block diagram, the module contains a single Light Emitting Diode (LED) as its light source. The light is collimated into a parallel beam by means of a single lens located directly over the LED. Opposite the emitter is the integrated detector circuit.

This IC consists of multiple sets of photodetectors and the signal processing circuitry necessary to produce the digital waveforms.

The codestrip moves between the emitter and detector, causing the light beam to be interrupted by the pattern of spaces and bars on the codestrip. The photodiodes which detect these interruptions are arranged in a pattern that corresponds to the count density of the

## Features

- Small size
- Multiple mounting options
- Wide resolution range
- Linear options available
- No signal adjustment required
- Insensitive to radial and axial play
- $-40^{\circ}\text{C}$  to  $+85^{\circ}\text{C}$  operating temperature
- High resolution version of the HEDS-970x
- Two-channel quadrature output
- TTL or 5.0 V CMOS compatible
- Single 5 V supply
- Wave solderable
- Integrated 2.5 K $\Omega$  pullup on outputs

codestrip. These detectors are also spaced such that a light period on one pair of detectors corresponds to a dark period on the adjacent pair of detectors. The photodiode outputs are fed through the signal processing circuitry. Two comparators receive these signals and produce the final outputs for channels A and B. Due to this integrated phasing technique, the digital output of channel A is in quadrature with channel B (90 degrees out of phase).

**ESD WARNING: NORMAL PRECAUTIONS SHOULD BE TAKEN TO AVOID STATIC DISCHARGE.**



Agilent Technologies

**Definitions**

Count (N) = the number of bar and window pairs or Counts Per Revolution (CPR) of the codewheel, or the number of Lines Per Inch (LPI) of the codestrip.

$$1 \text{ Shaft Rotation} = 360 \text{ mechanical degrees} \\ = N \text{ cycles}$$

$$1 \text{ Cycle (c)} = 360 \text{ electrical degrees (e)} \\ = 1 \text{ bar and window pair}$$

**Pulse Width (P):** The number of electrical degrees that an output is high during one cycle. This value is nominally 180°e or 1/2 cycle.

**Pulse Width Error ( $\Delta P$ ):** The deviation, in electrical degrees, of the pulse width from its ideal value of 180°e.

**State Width (S):** The number of electrical degrees between a transition in the output of channel A and the neighboring transition in the output of channel B. There are four states per cycle, each nominally 90°e.

**State Width Error ( $\Delta S$ ):** The deviation, in electrical degrees, of each state width from its ideal value of 90°e.

**Phase ( $\phi$ ):** The number of electrical degrees between the center of the high state of channel A and the center of the high state of channel B.

This value is nominally 90°e for quadrature output.

**Phase Error ( $\Delta\phi$ ):** The deviation of the phase from its ideal value of 90°e.

**Direction of Rotation:** When the codewheel rotates counter-clockwise, as viewed looking down on the module (so the marking is visible), channel A will lead channel B. If the codewheel rotates in the opposite direction, channel B will lead channel A.

**Optical Radius ( $R_{OP}$ ):** The distance from the codewheel's center of rotation to the optical center (OC) of the encoder module.

**Angular Misalignment Error ( $E_A$ ):** Angular misalignment of the sensor in relation to the tangential direction. This applies for both rotary and linear motion.

**Mounting Position ( $R_M$ ):** Distance from motor shaft center of rotation to center of alignment tab receiving hole.

**Absolute Maximum Ratings**

Parameter	Symbol	Min.	Max.	Units	Notes
Storage Temperature	$T_S$	-40	85	°C	
Operating Temperature	$T_A$	-40	85	°C	
Supply Voltage	$V_{CC}$	-0.5	7	V	
Output Voltage	$V_O$	-0.5	$V_{CC}$	V	
Output Current per Channel	$I_O$	-1.0	5	mA	
Soldering Temperature			260	°C	$t \leq 5 \text{ sec.}$

**Recommended Operating Conditions**

Parameter	Symbol	Min.	Typ.	Max.	Units	Notes
Temperature	T	-40		85	°C	
Supply Voltage	V <sub>CC</sub>	4.5	5.0	5.5	V	Ripple < 100 mVp-p. Recommended one bypass capacitor (1 µF) between V <sub>CC</sub> and GND less than 15 cm from the encoder.
Load Capacitance	C <sub>L</sub>			100	pF	
Pullup Resistor	R <sub>L</sub>		none			Recommended no pullup. Device has integrated 2.5 kΩ on outputs.
Count Frequency				40	kHz	(Velocity (rpm) x N) / 60
Angular Misalignment	E <sub>A</sub>	-2.0	0	+2.0	deg.	Mounting considerations.

**Electrical Characteristics over Recommended Operating Range, Typical at T<sub>A</sub> = 25°C**

Parameter	Symbol	Min.	Typ.	Max.	Units	Notes
Supply Current	I <sub>CC</sub>	12	21	40	mA	
High Level Output Voltage	V <sub>OH</sub>	2.4			V	I <sub>OH</sub> = -200 µA
Low Level Output Voltage	V <sub>OL</sub>			0.4	V	I <sub>OL</sub> = 3.2 mA
Rise Time	t <sub>r</sub>		70		ns	C <sub>L</sub> = 25 pF
Fall Time	t <sub>f</sub>		45		ns	R <sub>L</sub> = (NO pullup)

**Encoding Characteristics**

Encoding Characteristics over Recommended Operating Range and Recommended Mounting Tolerances. These characteristics do not include codewheel/codestrip contribution. The Typical Values are averages over the full rotation of the codewheel.

Parameter	Symbol	Typical	Maximum	Units
Pulse Width Error	ΔP	5	40	°e
Logic State Width Error	ΔS	3	40	°e
Phase Error	Δφ	2	15	°e

## Recommended Codewheel and Codestrip Characteristics

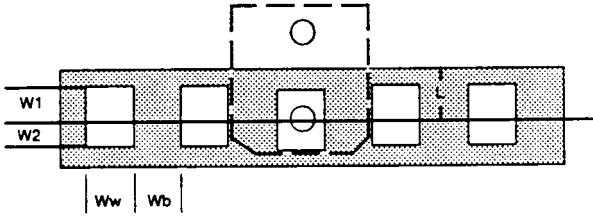

Parameter	Symbol	Min.	Max.	Units	Notes
Window/Bar Ratio	Ww/Wb	0.7	1.4		
Center of Post to Inside Edge of Window	W1	1.04 (0.041)		mm (inch)	
Center of Post to Outside Edge of Window	W2	0.76 (0.030)		mm (inch)	
Center of Post to Inside Edge of Codestrip	L		3.60 (0.142)	mm (inch)	

## Mounting Considerations

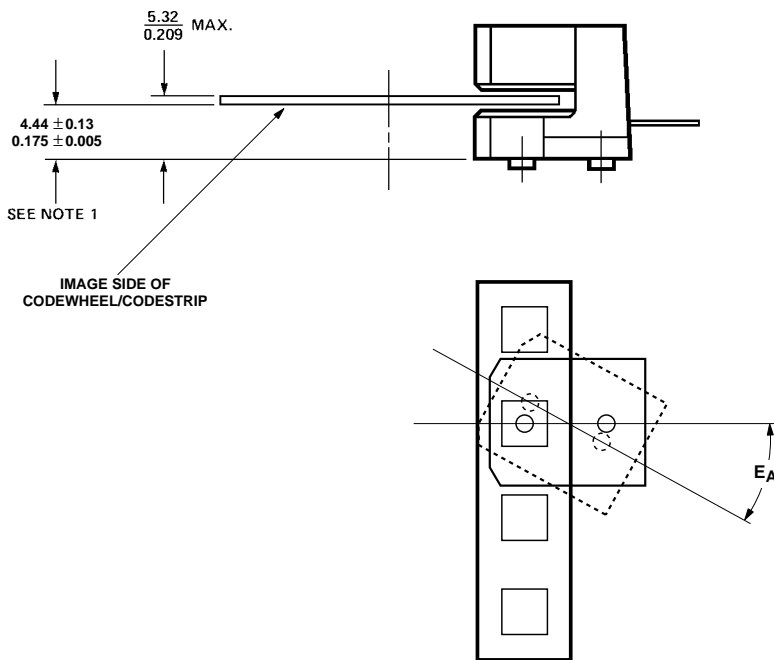

For linear motion, angular misalignment,  $E_A$ , must be  $\leq \pm 2$  degrees to achieve Encoding Characteristics.

All dimensions for mounting the module and codestrip should be measured with respect to the two mounting posts, shown above.

**Recommended Screw Size:** M2.5 x 0.45 or 2-56

**Recommended Wave Solder Conditions**

**Flux** – RMA Water Soluble (per MIL-F-14256D)

**Process Parameters**

1. Flux
2. Pre-heat 60 seconds total  
Nominal preheat temp: 90°C  
Min: 85°C Max: 110°C
3. Solder Pot Zone  
Nominal dip in time:  
2.5 - 4.5 seconds  
Min: 2.5 seconds  
Max: 5 seconds  
PCB top side: 140 -160°C  
PCB bottom side: 240 - 260°C
4. Wave Solder 255°C,  
1.2 meters/minute line speed
5. Hot Water Wash  
1st: 30°C 45 seconds  
2nd: 70°C 90 seconds
6. Rinse  
1st: 23°C 45 seconds  
2nd: 23°C 45 seconds
7. Dry  
1st: 80°C 105 seconds  
2nd: 95°C 105 seconds

**Ordering Information**

HEDS-974  Option

<b>Lead Bend</b> 0 – Straight Leads 1 – Bend Leads	<b>Resolution Options</b> Q – 180 LPI, linear 2 – 300 LPI, linear 1 – 360 LPI, linear	<b>Mounting Options</b> 50 – Standard
--	--	--

		50	51	52	53	54	55
HEDS-9740	Q	*					
	2	*					
	1	*					
HEDS-9741	Q						
	2	*					
	1						

**Package Dimensions**

Mounting Option #50

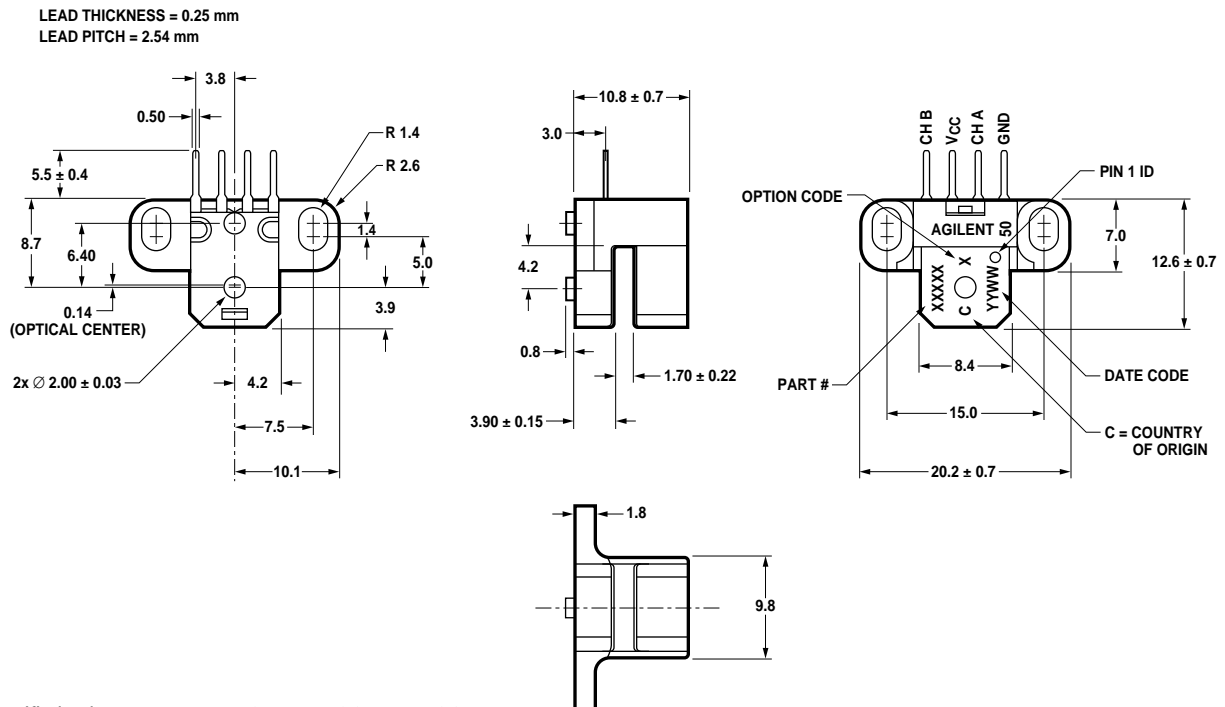

**Note:**  
If not specified, tolerances are xx. ± 0.7, xx.x ± 0.3, xx.xx ± 0.07 mm.

**[www.agilent.com/semiconductors](http://www.agilent.com/semiconductors)**

For product information and a complete list of distributors, please go to our web site.

For technical assistance call:

Americas/Canada: +1 (800) 235-0312 or  
(408) 654-8675

Europe: +49 (0) 6441 92460

China: 10800 650 0017

Hong Kong: (+65) 6271 2451

India, Australia, New Zealand: (+65) 6271 2394

Japan: (+81 3) 3335-8152(Domestic/International), or 0120-61-1280(Domestic Only)

Korea: (+65) 6271 2194

Malaysia, Singapore: (+65) 6271 2054

Taiwan: (+65) 6271 2654

Data subject to change.

Copyright © 2002 Agilent Technologies, Inc.

Obsoletes 5988-6067EN

October 2, 2002

5988-8042EN



**Agilent Technologies**